

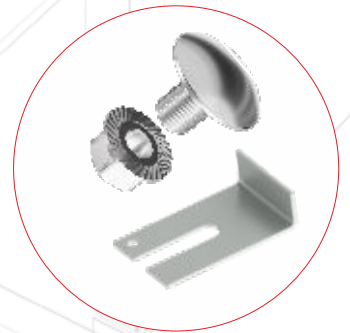

KOPOS

# INSTALLATION INSTRUCTIONS

## CABLE MANAGEMENT SYSTEMS

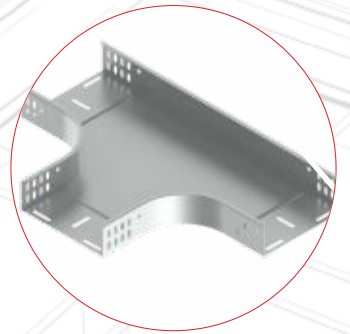
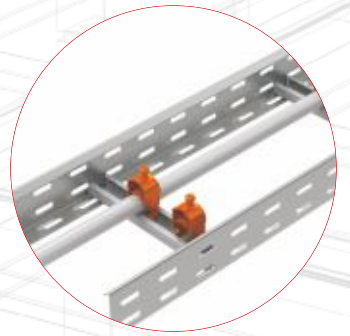



## Transport and storage

### • Transport

During transport, all components of the cable management system must be properly fastened to the loading area of a transport vehicle. In case the cable trays are placed on a pallet, a forklift can be used for unloading. If material is free loaded, the unloading is required preferably by hand. This will significantly reduce the risk of a cable trays damage. Use extreme caution and ensure work safety during loading and unloading. For sea transport, it is appropriate to use packaging intended specifically for this type of transport.

**ATTENTION!!:** Trays, ladders and their accessories can be damaged during handling and transport. In case of individual elements damage we do not recommend subsequent installation due to nonobservance of the allowed loading and corrosion protection.

### • Storage

Cable management systems and other system components should be stored in dry areas. Storage in humid or outdoor conditions can lead to white corrosion. According to the standard, this cosmetic defect is not a cause for complaint and it is a natural chemical process of zinc hydroxide beginning. Access of the air is also important during storage. Especially when stored outdoors and covered with an airtight sheet, moisture condensation and complete devastation of stored material by corrosion occurs.

Overseas packaging which ensures protection from the marine environment influences must be used when ship transporting.

## Assembly of supporting elements

### • Supporting system

The distance of cable system supports depends on cable trays loading and is given by a project. To determine support distances and options loading of cable trays it is also possible to use the information (load charts), which are listed in the catalog Cable management systems. This is available in a paper form or on [www.kopos.com](http://www.kopos.com).

Suitable fasteners must be used for support system mounting. These must be chosen with regard to the material of the walls on which supporting elements are fastened. The specified drill hole depth must also be observed. Details are given in the catalog or in catalogs of individual fastener manufacturers.

The cable system can also be installed on a building steel structure. As in case of fixing to walls and ceilings, in this case it is also necessary to consider the mechanical load capacity of the structures with regard to the loads that the installation of cable management systems will cause.

### • Cable tray accessories

The elements used for the branching of a cable route (curves, T-pieces, crosses, etc.) are connected using screws or flexible clamps. The number of screws and other information are listed in the catalog.

Another important aspect of the assembly is the creation of expansion gaps, as thermal length expansion can be (especially in larger systems) quite considerable.

The cutting of cable routes is the best to do with using an angle grinder (flex). Use an edge shelter to cover the edges to protect the cables as well as workers who come into contact with cable systems.

The parts of cable trays, accessories or support systems that have been damaged by cutting, drilling or other means should be treated with zinc spray or zinc paint.

It is recommended to use special tools for stainless steel when cutting and adjusting of stainless steel products. This will prevent unwanted transmission of other material particles that can start to corrode and thus disrupt the structure of stainless steel.

## Grounding and bonding

When connection of cable trays using integrated coupling and NSM 6X10 bolts, their connection is ensured. It is tested in accordance with ČSN EN 61357 standard where are routes with characteristics of electric continuity for securing of protective connection and connection with ground, according to articles 6.3.2. During the test, the alternating current of 25 A run through cable trays and the loop impedance must be less than 50 mΩ. The cable trays have stood the test.

## Corrosion resistance

The cable trays are supplied in various surface treatments that meet requirements for placing cable management systems in environments with different influences. The risk of corrosion depends on the intensity of external influences according to ČSN EN ISO 14713-1 and ČSN EN ISO 14713-2. The classification is divided into degrees C1-C5. More information is available in the catalog.

## Surface treatments

- **Pre-galvanizing by Sendzimir method**

According to the standard ČSN EN 10 143, ČSN EN 10346 - Steel sheets and strips continuously metal plated.

After preparation, the cold rolled steel strip passes through the continuous bath of liquid zinc. The resulting zinc layer guarantees increased protection from corrosion, zinc layer 15-27  $\mu\text{m}$  (or 10-22  $\mu\text{m}$ ).

Suitable for indoor environment.

- **Magnelis® - Zinc Coating with Zn + Al + Mg Alloy**

According to standards ČSN EN 10143, ČSN EN 10346 – Continuously Hot-Dip Coated Steel Sheets and Strips.

A cold-rolled steel strip undergoes a cleaning and pickling process before passing through a zinc alloy bath containing 3.5% aluminum and 3% magnesium. The resulting zinc coating provides enhanced corrosion protection, with a zinc layer thickness of 18–31  $\mu\text{m}$ .

The surface treatment has a self-healing property, ensuring gradual protection on cut edges of the material.

Suitable for indoor and outdoor environments.

- **Hot Dip Galvanizing**

According to ČSN EN ISO 1461 - Hot dip galvanized zinc coating

The finished products from sheet without any surface treatment are sunk into a zinc bath at the temperature of approximately 450°C. A layer of iron and zinc alloy covered with a layer of pure zinc is formed on steel after removing from the zinc bath.

The layer of zinc layer depends on the thickness of the material. For material of <1.5 mm thick, the average zinc layer is 45  $\mu\text{m}$  according to the standard.

Suitable for outdoor environment.

- **Galvanizing - zinc chromate**

According to ČSN EN ISO 2081 - Metallic and other inorganic coatings - Electrolytically deposited zinc coatings with additional treatment on iron or steel.

Galvanizing in electrolytic bath - protective coating layer 10 $\pm$ 4  $\mu\text{m}$ .

This surface treatment is mainly used for fasteners, screws, nuts, washers, anchors, threaded rods, supports...

Suitable for indoor environment.

- **GEOMET - non-electrolytic plating**

Inorganic microlayer base system with cathodic protection of surfaces, electrical conductive, with high protective efficiency in salt spray test according to ISO 9227, ASTM B 117-73 and DIN 50021.

Protective coating layer 5-15  $\mu\text{m}$ .

This surface treatment is mainly used for fasteners and accessories of smaller dimensions (e.g. couplings).

Suitable for outdoor environment.

- **Painting**

The coating not only increases the corrosion resistance in an aggressive environment, but also meets the higher requirements for esthetics.

A powder coating is applied to the galvanized sheet product in the electrostatic field. This is followed by firing the products in a burning furnace where the powder is melted, cured and adhered to the surface.

Coated products are UV-resistant.

- **Stainless steel**

AISI 304 (DIN 1.4301)

Standard stainless steel is resistant to water, water vapor, air humidity, edible acids and slight organic and inorganic acids. It resists weathering outside the coastal areas or outside environments where the concentration of aggressive chemicals is higher. It has a wide spectrum of using. Used in the food industry, chemical industry, dairy industry, brewing industry, wine industry, pharmaceutical industry and cosmetic industry.



### cable trays with intergrated coupling connection

connection fastening with screws NSM 6X10

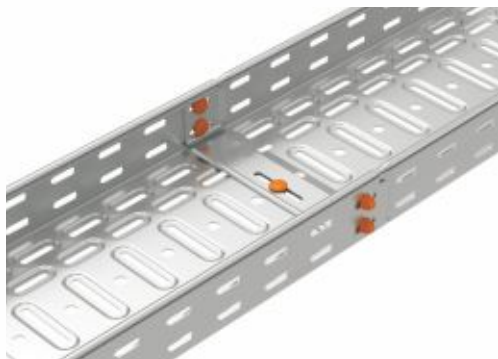

connection fastening with KSV clamps



connecting material quantity for one connection (pcs)

cable tray width	cable tray height					
	35	50	60	85	100	110
50	2	-	4	-	-	-
62	-	2	-	-	-	-
75	2	-	4	-	-	-
100	2	-	4	6	-	-
125	-	2	-	-	4	-
150	2	-	4	6	-	8
200	3	-	5	7	-	9
250	-	3	-	-	5	-
300	3	-	5	7	-	9
400	4	-	6	8	-	10
500	4	-	6	8	6	10
600	4	-	6	8	-	10

### cable trays without integrated coupling connection and cable ladders connection

cable trays JUPITER

connection with S ... X200 couplings

connection fastening with bolts NSM 6X10



cable ladders (stainless steel)

connection with S ... X200 (INOXS ...) couplings

connection fastening with bolts NSM 6X10 (NIXSM 6X10)

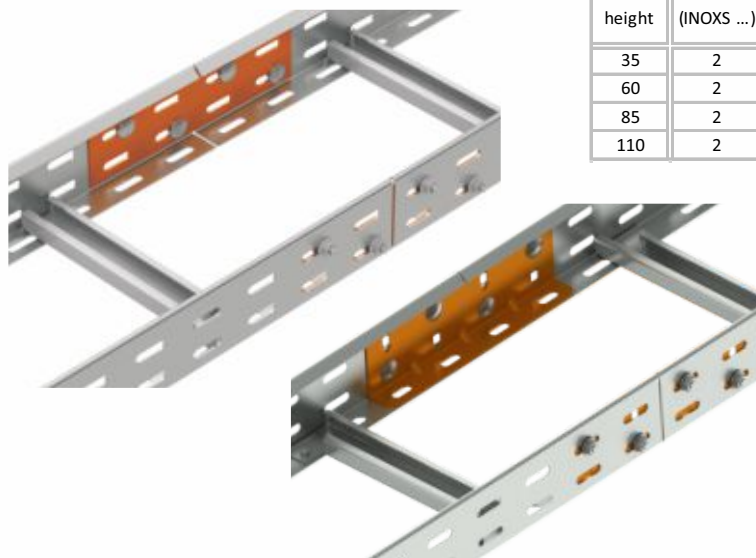

cable tray/ladder height	quantity of couplings S ..X200 (INOXS ...)	minimum quantity of bolts NSM 6X10 (NIXSM 6X10)
35	2	8
60	2	8
85	2	12
110	2	16

cable trays MARS

connection with NS couplings

connection fastening with bolts NSM 6X10

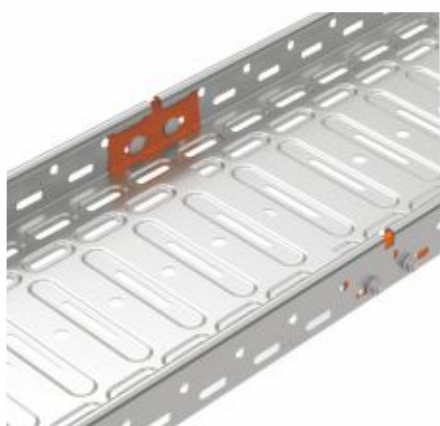

cable trays MARS - stainless steel

connection with NIXS couplings

connection fastening with bolts NIXSM 6X10



cable tray height	quantity of couplings NS (NIXS)	minimum quantity of bolts NSM 6X10 (NIXSM 6X10)
50	2	4
100	2	8

### reinforcement of cable trays/ladders connection

connection with supporting corners UP  
connection fastening with bolts NSM 6X10

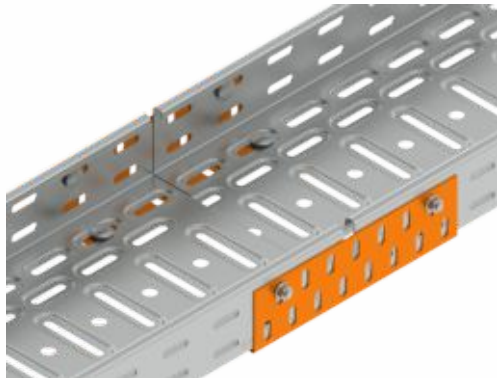

cable tray/ ladder height	supporting corner		minimum quantity of bolts
	type number	quantity	
35	UP 35X42	2	8
60	UP 60X85	2	8
85	UP 60X85	2	8
110	UP 110	2	8

connection with couplings S ...X200  
connection reinforcement with DV reinforcing plate  
connection fastening with bolts NSM 6X10



cable tray height	cable tray width	quantity of couplings S...X200	quantity of reinforcing plates DV	minimum quantity of bolts NSM 6X10
35	75-200	2	1	12
35	300-600	2	1	16
60	75-200	2	1	12
60	300-600	2	1	16
85	75-200	2	1	16
85	300-600	2	1	20
110	75-200	2	1	20
110	300-600	2	1	24



#### bolts NSM 6X10\_ZNCR / NSM 6X10\_GMT / NIXSM 6X10\_IX

- fastening with bolts and nuts ensures conductive connection up to 25 A
- bolt tightening moment - 9,7 Nm
- key size 10
- bolt mounting is with head inside the tray (cable ladders, fittings) = cable protection
- bolts NSM 6X10-GMT are intended for cable trays (cable ladders, fittings) of configuration F (hot dip galvanized) connection
- bolts NIXSM 6X10\_IX are intended for stainless steel systems connection
- the number of bolts used is listed in Cable management systems catalogue

### covers fastening

- cable tray and cable ladder covers are fastened with VU cover fixtures
- the fixture is placed to the cover and the sidewall in the place of opening and it is slightly pressed so that the fixture lock slides into the opening
- nonperforated trays have 3 openings in the sidewall prepared for cover fastening with cover fixtures VU
- covers for cable trays and walkways are attached using the NUV cover clamp and NSM 6x10 bolts
- for fastening, it is recommended to use a screw that ensures the connection between trays or between a tray and a fitting.
- covers for stainless steel cable trays and fittings are attached using the NIXUV cover clamp and NIXSM 6x10 bolt
- for fastening, it is recommended to use a bolt that ensures the connection between trays or between a tray and a fitting
- covers for stainless steel cable ladder and fittings are attached using the INOXUV cover clamp and NIXSM 6x10 bolt
- for fastening, it is recommended to use a bolt that ensures the connection between trays or between a ladder and a fitting

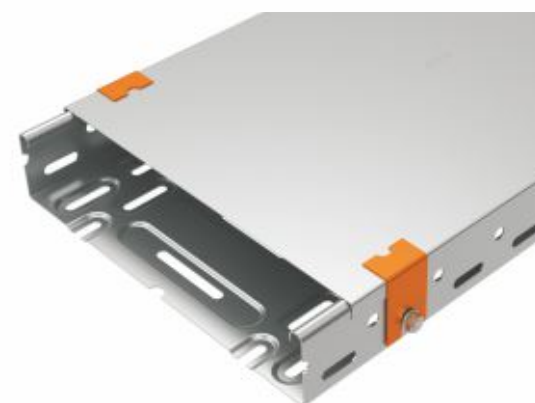

### interior space of cable trays and cable ladders partition

- partitions P, NPZ, NIXP are intended to split the space
- partition fastening into a cable tray with NSM 6X10 (NIXSM 6X10) bolt every 0.5 m
- partition fastening into a cable ladder with NSM 6X20 bolt every 0.6 m
- it is necessary to drill holes to the bottom of non-perforated cable tray (KZIN, NKZIN, NIXKZN) to fix the partition

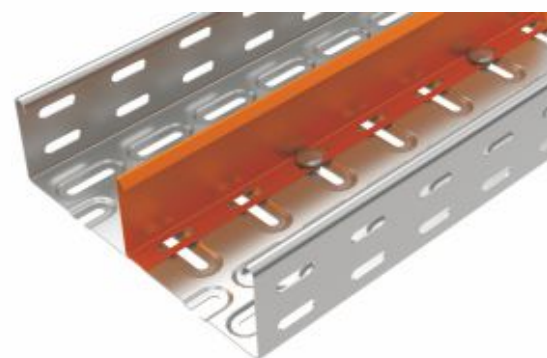

### fittings for cable trays

- elbows, T-pieces, cross-overs ...
- cable tray is inserted into a fitting, the connection is fastened with NSM 6X10 (NIXSM 6X10) bolts
- minimum number of bolts required for the connection is shown in the table
- cable tray is cut to the required length, e.g. using an angle grinder
- the cutting must be cleaned from burrs and threaded with zinc spray or paint
- the mounting of all bolts is the head inside the tray

### fitting covers for cable trays

- covers are fastened to fittings with VU cover fixtures
- the number of fixtures for fixing is determined with the number of openings in the fitting
- the fixture is placed to the cover and the sidewall in the place of the opening and it is slightly pressed so that the fixture lock slides into the opening
- covers are fastened to fittings with NUV cover fixtures and NSM 6X10 (NIXSM 6X10) bolt
- fastening (fixture insertion) can be made under the bolt which ensures cable tray and fitting connection

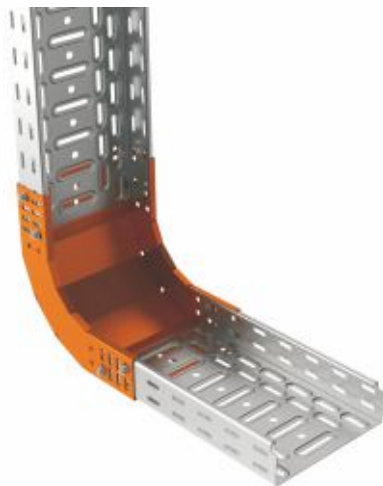
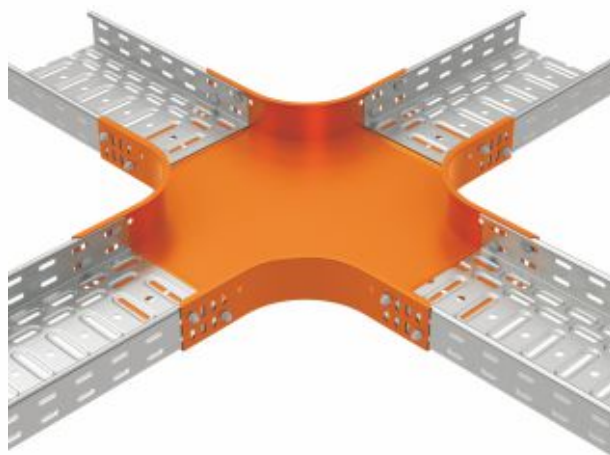
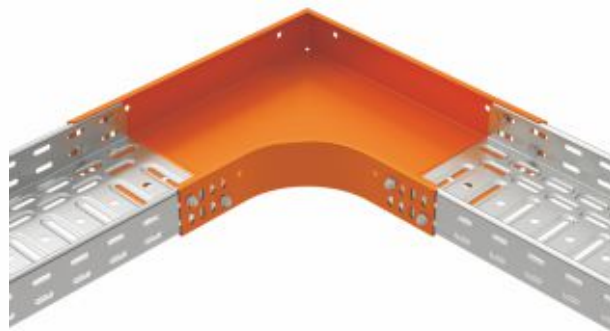

### fittings for cable ladders

- horizontal elbows, T-pieces, cross-overs
- fitting and ladder connection with S...X200 couplings and NSM 6X10 bolts
- the number of couplings and bolts is the same as the information on page 4 - connection with S..X200 coupling table
- cable ladders are cut to the required length, e.g. using an angle grinder
- the cutting should be cleaned from burrs and treated with zinc spray or paint
- the assembly of all bolts is the head inside the ladder

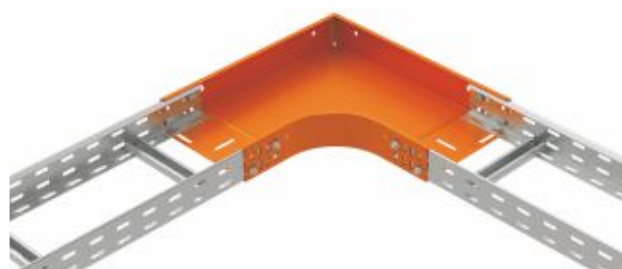

- fittings for cable trays can be used also for cable ladders (bending radius only 100 mm)
- the cable ladder is inserted into a fitting, the connection is fastened with NSM 6X10
- the assembly of all bolts is the head inside the ladder



### route bending at any angle - vertically

- **hinged coupling SK (INOXSK)**
- the coupling is mounted inside a cable tray or a cable ladder
- bolts NSM 6X10 (NIXSM 6X10) are intended for connection fastening
- the assembly of all bolts is the head inside the tray (ladder)
- cable trays are cut to the required length e.g. using an angle grinder
- the cutting has to be cleaned from burrs and treated with zinc spray or paint
- the tray edge should be fitted with an edge protector NCH

cable tray /cable ladder height	couplings quantity SK (INOXSK)	minimum quantity of bolts NSM 6X10 (NIXSM 6X10)
35	2	8
50	2	8
60	2	8
85	2	12
100	2	8
110	2	16

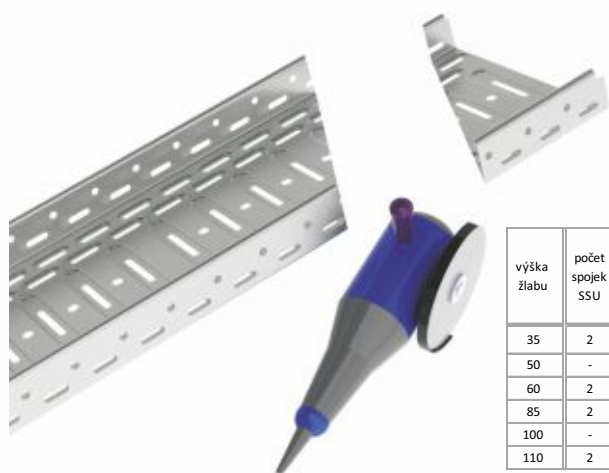
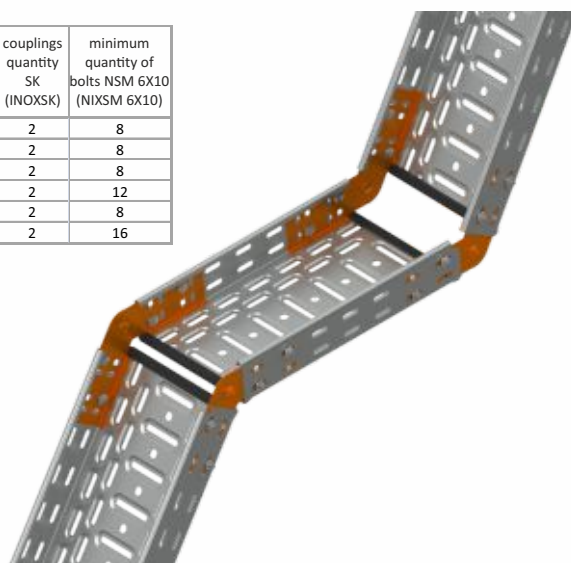

výška žlabu	počet spojek SSU	počet spojek NSUK (NIXSUK)	min. počet šroubů NSM 6X10 (NIXSM 6X10)
35	2	-	8
50	-	2	4
60	2	-	8
85	2	-	12
100	-	2	8
110	2	-	16



### route bending at any angle - horizontally

- **angle coupling SSU, NSUK (NIXSUK)**
- connected trays are cut to required angle
- the cutting has to be cleaned from burrs and treated with zinc spray or paint
- it is recommended to use special tools for stainless steel when cutting and adjusting of stainless steel products. This will prevent unwanted transfer of other material particles that can start to corrode and thus disrupt the structure of stainless steel.
- any angle can be created by bending of the coupling
- the coupling is mounted inside the cable tray
- bolts NSM 6X10 are intended for connection fastening
- the assembly of all bolts is the head inside the tray



### route bending at any angle, branching - horizontally

- **horizontal side wall clamp BSKH (INOXBSKH) - cable ladders**
- connected ladders are cut to the required shape, angle
- the cutting has to be cleaned from burrs and treated with zinc spray or paint
- when branching the route, the sidewalls of the cable ladder are cut approximately 15 mm above bottom - in the axis of the bottom row of punching the edge must be equipped with edge protector NCH
- any angle can be created by the clamp bending
- the clamp is mounted inside the cable ladder
- bolts NSM 6X10 (NIXSM 6X10) are intended for connection fastening
- the assembly of all bolts is the head inside the tray



horizontal side wall clamp	minimum quantity of bolts NSM 6X10 (NIXSM 6X10)
BSKH 60 K (INOXBSKH 60 K)	4
BSKH 60 D (INOXBSKH 60 D)	8
BSKH 85 K	6
BSKH 85 D	12
BSKH 110 K (INOXBSKH 110 K)	8
BSKH 110 D (INOXBSKH 110 D)	16

### additional branching or branching to another width of the tray

- **reduction piece NRD, SU**
- at running and branching trays side walls must be cut off
- bolts NSM 6X10 are intended for connection fastening
- cable trays are cut to the required length e.g. using an angle grinder
- the cutting has to be cleaned from burrs and treated with zinc spray or paint
- the assembly of all bolts is the head inside the tray

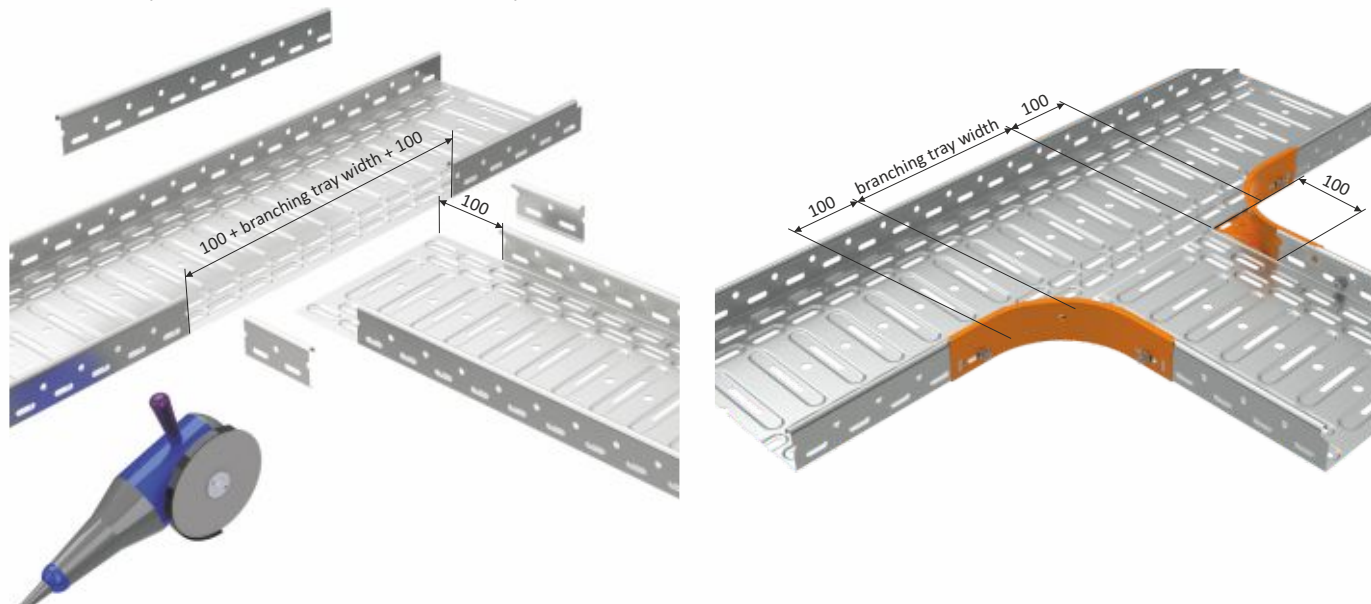

### route width change

#### reduction K-R, NIXR

- the K-R reduction is formed by bending the ends into the required shape
- when changing the route width from both sides 2 pcs of reduction are used
- in case of one-sided route width change 1 reduction piece and 1 coupling piece S... X200, NS or NIXS are used
- bolts NSM 6X10 (NIXSM 6X10) are intended for connection fastening
- the cable tray (ladder) is cut to the required length, e.g. using an angle grinder
- the cutting has to be cleaned from burrs and treated with zinc spray or paint
- the assembly of all bolts is with the head inside the tray (ladder)

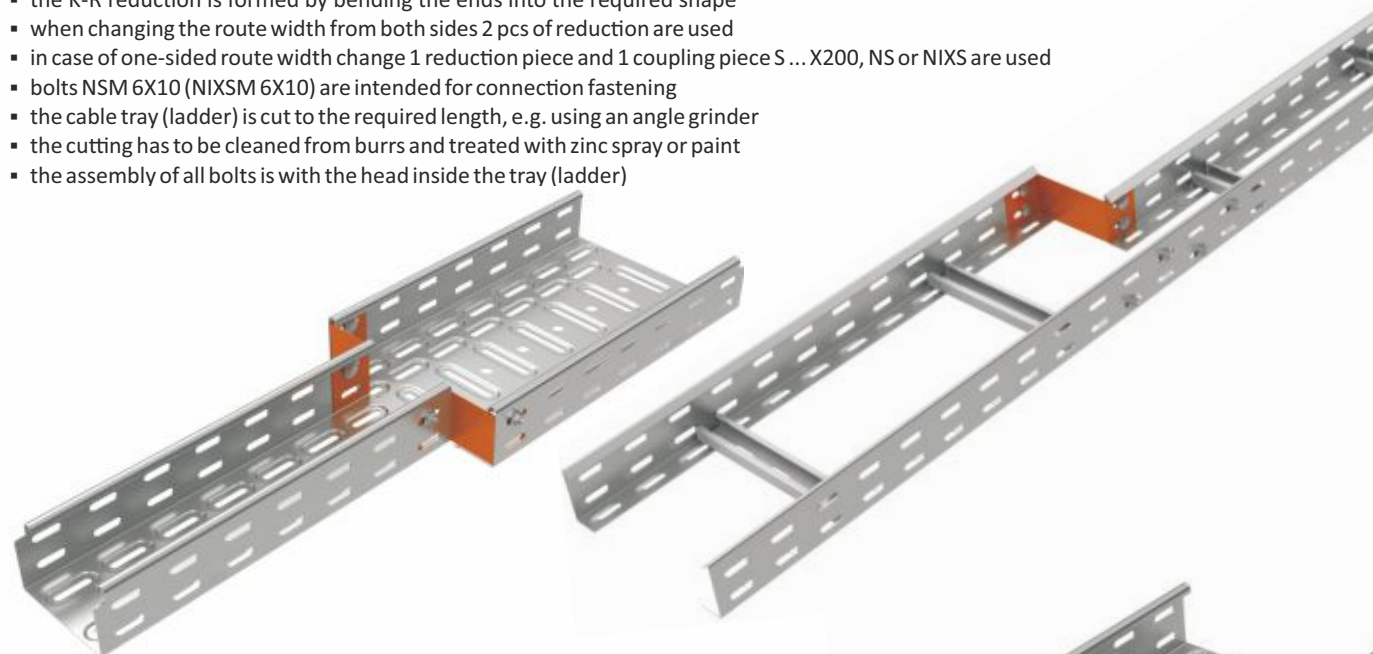

### route ending

#### end-piece K-R, NIXK

- the K-R end-piece is formed by bending the ends into the required shape
- bolts NSM 6X10 (NIXSM 6X10) are intended for connection fastening
- the cable tray (ladder) is cut to the required length, e.g. using an angle grinder
- the cutting has to be cleaned from burrs and treated with zinc spray or paint
- the assembly of all bolts is with the head inside the tray (ladder)



minimum number of bolts required to ensure the connection between a tray (ladder) and a fitting

cable tray/ladder size v x š	elbow 90°		elbow 45°	rising elbow 90°		low elbow 90°		T-piece		cross-over		horizontal brach	reduction piece		hinged coupling	reduction/end-piece
	O 90x V x Š	NO 90x V x Š	NO 45x V x Š	SO 90x V x Š	NSO 90x V x Š	KO 90x V x Š	NKO 90x V x Š	TV x Š	NTV x Š	KR V x Š	NKR V x Š	OH V x Š	SU	NRD	SK	K-R V x Š
35x50	8	-	-	8	-	8	-	12	-	16	-	8	4	-	4	2
35x75	8	-	-	8	-	8	-	12	-	16	-	8	4	-	4	2
35x100	8	-	-	8	-	8	-	12	-	16	-	8	4	-	4	2
35x150	8	-	-	8	-	8	-	12	-	16	-	8	4	-	4	2
35x200	10	-	-	10	-	10	-	15	-	20	-	9	4	-	4	2
35x300	10	-	-	10	-	10	-	15	-	20	-	9	4	-	4	2
35x400	12	-	-	12	-	12	-	18	-	24	-	10	4	-	4	2
35x500	12	-	-	12	-	12	-	18	-	24	-	10	4	-	4	2
35x600	12	-	-	12	-	12	-	18	-	24	-	10	4	-	4	2
60x50	8	-	-	8	-	8	-	12	-	16	-	8	4	-	4	4
60x75	8	-	-	8	-	8	-	12	-	16	-	8	4	-	4	4
60x100	8	-	-	8	-	8	-	12	-	16	-	8	4	-	4	4
60x150	8	-	-	8	-	8	-	12	-	16	-	8	4	-	4	4
60x200	10	-	-	10	-	10	-	15	-	20	-	9	4	-	4	4
60x300	10	-	-	10	-	10	-	15	-	20	-	9	4	-	4	4
60x400	12	-	-	12	-	12	-	18	-	24	-	10	4	-	4	4
60x500	12	-	-	12	-	12	-	18	-	24	-	10	4	-	4	4
60x600	12	-	-	12	-	12	-	18	-	24	-	10	4	-	4	4
85x100	16	-	-	16	-	16	-	24	-	32	-	16	8	-	8	4
85x150	16	-	-	16	-	16	-	24	-	32	-	16	8	-	8	4
85x200	18	-	-	18	-	18	-	27	-	36	-	17	8	-	8	4
85x300	18	-	-	18	-	18	-	27	-	36	-	17	8	-	8	4
85x400	20	-	-	20	-	20	-	30	-	40	-	18	8	-	8	4
85x500	20	-	-	20	-	20	-	30	-	40	-	18	8	-	8	4
85x600	20	-	-	20	-	20	-	30	-	40	-	18	8	-	8	4
110x150	16	-	-	16	-	16	-	24	-	32	-	16	8	-	8	4
110x200	18	-	-	18	-	18	-	27	-	36	-	17	8	-	8	4
110x300	18	-	-	18	-	18	-	27	-	36	-	17	8	-	8	4
110x400	20	-	-	20	-	20	-	30	-	40	-	18	8	-	8	4
110x500	20	-	-	20	-	20	-	30	-	40	-	18	8	-	8	4
110x600	20	-	-	20	-	20	-	30	-	40	-	18	8	-	8	4
50x62	-	4	4	-	4	-	4	-	6	-	8	-	-	2	4	2
50x125	-	4	4	-	4	-	4	-	6	-	8	-	-	2	4	2
50x250	-	4	4	-	4	-	4	-	6	-	8	-	-	2	4	2
100x125	-	8	8	-	8	-	8	-	12	-	16	-	-	4	8	4
100x250	-	8	8	-	8	-	8	-	12	-	16	-	-	4	8	4
100x500	-	8	8	-	8	-	8	-	12	-	16	-	-	4	8	4

h = height  
w = width



### hanging on one threaded rod

- **outer hanger ZVNE**
- the hanger is inserted into a cable tray, the hanging is carried out
- by the bent hem of hanger behind the bent hem of the cable tray/ladder sidewall
- MN nut is inserted into the hole in the hanger from the bottom
- the nut dimension is chosen according to the dimension of the threaded rod (MN 8 + ZT 8 or MN 10 + ZT 10)

Product list for one mounting point	
ZVNE	1
MN	1
ZT	1
KKZ, KKZM, KPOZ, DSOS, DSZT, DSS, US	1

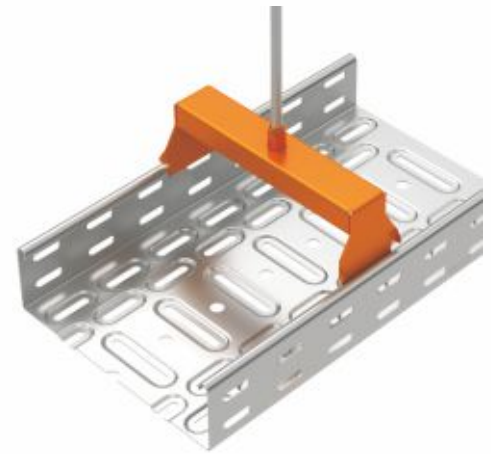

### hanging on one threaded rod

- **inner hanger ZVNI**
- MN nut is inserted into the hole in the hanger from the bottom
- the nut dimension is chosen according to the dimension of the threaded rod (MN 8 + ZT 8 or MN 10 + ZT 10)
- the hanger with the nut is inserted into the cable tray, the hanger is fixed with bolts NSM 6X10 (4 pcs) to sidewalls of the tray in the place of hanging
- the threaded rod must be screwed max. to the length of the nut

Product list for one mounting point	
ZVNI	1
MN	1
ZT	1
NSM 6X10 (ZVNI 50, 62, 75, 100, 150)	4
NSM 6X10 (ZVNI 200, 250)	6
NSM 6X10 (ZVNI 300, 400)	8
KKZ, KKZM, KPOZ, DSOS, DSZT, DSS, US	1

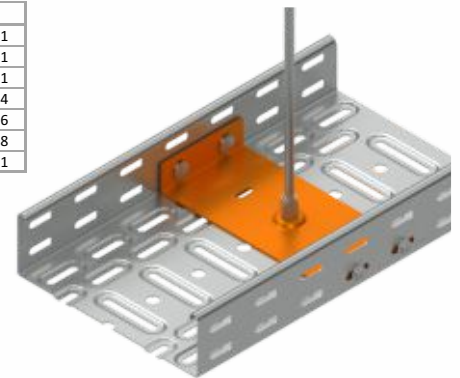

### hanging on one threaded rod - small trays

- cable trays KZI 35X50X ...; KZI 60X50X ...; NKZI 50X62X ... can be hung on a threaded rod only with large washers PVL and nuts M

Product list for one mounting point	
ZT	1
PVL	2
M	2
KKZ, KKZM, KPOZ, DSOS, DSZT, DSS, US	1

### hanging on two threaded rods

- **NP (INOXNP) load bearing profile**
- load bearing profiles NP 100 - NP 350 are intended for threaded rods ZT 8 + M 8 + PD 8
- load bearing profiles NP 450 - NP 650 are intended for threaded rods ZT 10 + M 10 + PD 10
- load bearing profiles INOXNP 250 - INOXNP 450 are intended for threaded rods INOXZT 8 + INOXM 8 + INOXPD 8
- a cable tray or a cable ladder are fixed to the load bearing profile with bolt NSM 6X10 (NIXSM 6X10)

Product list for one mounting point	
NP, INOXNP	1
ZT, INOXZT	2
M, INOXM	4
PD, INOXPD	4
NSM 6X10, NIXSM 6X10	2
KKZ, KKZM, KPOZ, INOXKPOZ, DSOS, DSZT, DSS, US	2

- **suspension piece NZ (NIXZ)**

- suspension pieces NZ (NIXZ) 62 - NZ (NIXZ) 250 are intended for threaded rod ZT (INOXZT) 8 + M (INOXM) 8 + PD (INOXPD) 8
- suspension piece NZ (NIXZ) 500 are intended for threaded rod ZT (INOXZT) 10 + M (INOXM) 10 + PD (INOXPD) 10
- a cable tray or a cable ladder are fixed to the load bearing profile with bolt NSM 6X10 (NIXSM 6X10)

Product list for one mounting point	
NZ, NIXZ	1
ZT, INOXZT	2
M, INOXM	4
PD, INOXPD	4
NSM 6X10, NIXSM 6X10	2
KKZ, KKZM, KPOZ, INOXKPOZ, DSOS, DSZT, DSS, US	2

- **assembly profile MP (INOXMP)**

- the assembly profile has to be cut to the required length according to the tray width
- suitable for ZT 8 (INOXZT 8) or ZT 10 (INOXZT 10) threaded rods
- fastening on threaded rods ZT 8 (INOXZT 8) => nut M 8 (INOXM 8) + washer PVL 8 (INOXPVL 8)
- fastening to threaded rods ZT 10 (INOXZT 10) => nut M 10 (INOXM 10) + washer PD 10 (INOXPD 10)
- a cable tray or a cable ladder are fastened to the assembly profile with NSM 6X20 (NIXSM 6X10) bolt and large washer PVL 6 (INOXPVL 6)

Product list for one mounting point	
MP, INOXMP	1
ZT, INOXZT	2
M, INOXM	4
PVL, INOXPVL	6
NSM 6X20, NIXSM 6X10	2
KKZ, KKZM, KPOZ, INOXKPOZ, DSOS, DSZT, DSS, US	2

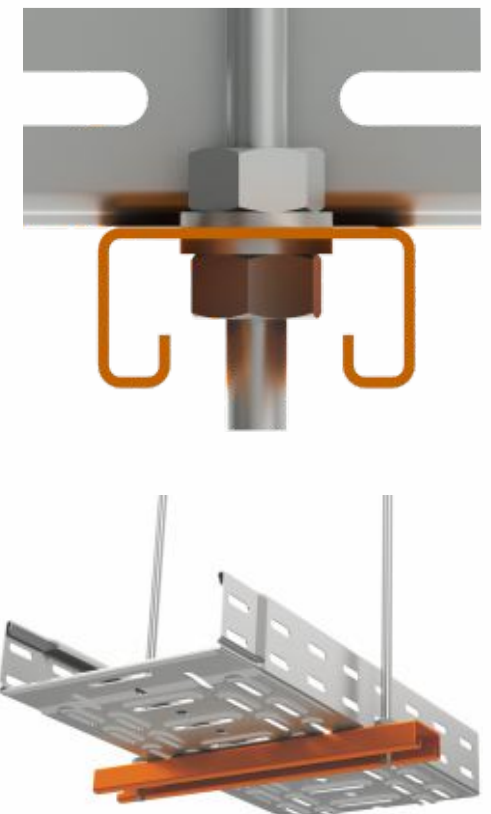



### hanging on two threaded rods

- **outer side hanger ZVB 1.5**
- the hanger is snapped using studs into the sidewall of a cable ladder or a cable tray with sheet thickness 1.5 mm
- a threaded rod ZT 8 is pushed through the hanger and fastened with a washer PD 8 and a nut M 8

Product list for one mounting point	
ZVB 1.5	2
ZT 8	2
M 8	2
PD 8	2
NSM 6X10	2
KKZ, KKZM, KPOZ, DSOS, DSZT, DSS, US	2

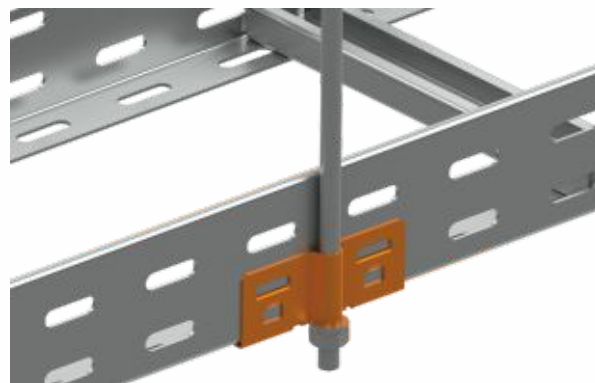

### threaded rods fastening

- **ceiling bracket DSZT**
- for threaded rod fastening to the ceiling
- opening 11x20 is intended for fixing to the ceiling for the anchor/bolt of dimension 8 or 10
- KPO anchors or stop anchors KKZ, KKZM + washers PD + bolts S are suitable for fastening
- Ø10.5 round opening is intended for threaded rod ZT 8 or ZT 10 hanging
- threaded rod fastening with a nut M and a washer PD

### threaded rods fastening

- **adjustable ceiling bracket DSS**
- for threaded rod fastening to the ceiling with a slight slope
- the top opening is intended to be fixed to the ceiling for anchor, bolt of dimension 8 or 10
- KPO anchors or stop anchors KKZ, KKZM + washers PD + bolts S are suitable for fastening
- opening is intended for threaded rod ZT 8 or ZT 10 hanging
- The threaded rod is secured using a M nut and PD washer (also suitable for retrofitting the threaded rod with a pre-screwed nut)

### threaded rods fastening

- **bracket for trapeze ceilings DSOS 8, DSOS 10**
- for threaded rod fastening to the trapezoidal metal ceiling
- after the hole creating in the trapeze sheet, the bracket is placed and M8x120 plug supplied is pulled the holes through the bracket and the metal sheet and this is ensured with supplied nuts and washers
- a threaded rod is screwed into an adjusted nut which is part of the bracket
- DSOS 8 or DSOS 10 bracket is chosen according to the dimension of ZT 8 or ZT 10 threaded rod

### threaded rods fastening

- **fixing clamp US 1, US 2, US 3**
- for threaded rod fixing to the I profile
- the clamp is pushed onto the I-profile and is fixed with a screw with the lock nut - the tightening moment is 8 Nm
- the threaded rod is screwed into the prepared hole and fastened with M nuts according to the dimension of the threaded rod
- fixing clamp US 1, US 2 or US 3 is chosen according to the dimension of the threaded rod ZT 8, ZT 10 or ZT 12

### threaded rods, bolts fastening

- **KKZ steel stop anchor**
- for threaded rods or bolts direct fixing
- dimensions for drilling the hole are listed in the catalog Cable management systems - following the dimensions is very important, wrong hole size may cause the damage of the anchor or insufficient fastening
- the opening for the anchor should be cleaned off
- insert the anchor into the hole
- beat the plug which is placed in the anchor with a hammer and a tool, until the edge of the anchor and the surface are in the same level
- suitable for the installation in non-cracked concrete, natural stone
- **KKZM brass stop anchor**
- for threaded rods or bolts direct fixing
- dimensions for drilling the hole are listed in the catalog Cable management systems - following the dimensions is very important, wrong hole size may cause the damage of the anchor or insufficient fastening
- the hole for the anchor should be cleaned off
- the anchor has an internal conical thread which expands when the threaded rod or bolt is mounted
- suitable for the installation in concrete, stone, wood, chipboard and solid brick



### hanging to the ceiling/wall

- **CTS hang clamp**
- the clamp is fixed to the ceiling/wall with 2 pcs of KPO 10X95 anchors or 2 pcs of KKZ 10 anchors + 2 pcs of bolts S 10x40 + 2 pcs of washers PD 10
- STS reinforcement which is intended to eliminate profile deformation is inserted into the profile before fastening to the ceiling/wall
- additional hanging in the form of a threaded rod ZT 8 or ZT 10 has to be ensured with a washer PD 8 (PD 10) + nut M 8 (M 10)
- for two-sided mounting two CTS clamps can be used, STS reinforcement is inserted into each clamp to eliminate profile deformation, the clamps and reinforcements are screwed with S 10X70 + 2 pcs of washers PD 10 + nut M 10
- cable tray/ladder fastening to the clamp with NSM 6X10 bolts

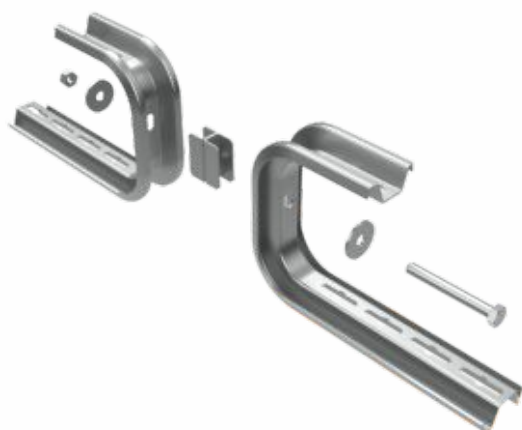

Product list for one mounting point - mounting to the ceiling	
CTS	1
STS	2
KPO 10X95	2
NSM 6X10	2

### hanging to the wall/ceiling

- **LTS bracket**
- the bracket is fixed to the wall/ceiling using 2 pcs of KPO 10X95 anchors or 2 pcs of KKZ 10 anchors + 2 pcs of bolts S 10x40 + 2 pcs of washers PD 10
- STS reinforcement, which is inserted into the profile before the fastening to the ceiling/wall, is intended to eliminate profile deformation
- for double-sided mounting it is possible to use the LTS bracket together with CTS clamp, to eliminate profile deformation the STS reinforcement, a bracket, a clamp and reinforcements are screwed with a screw S 10X70 + 2 pcs of washer PD 10 + nut M 10
- brackets can also be used as ceiling profiles which one or two brackets are fastened to
- single-sided mounting to the ceiling profile: the bracket is pushed onto another bracket intended as a ceiling profile and is fastened with 2 pcs of screw S 10X30 + 4 pcs of washer PD 10 + 2 pcs of nut M 10
- double-sided mounting to the ceiling profile: one bracket is pushed onto another bracket intended as a ceiling profile, the STS reinforcement is inserted between the second and the ceiling brackets, and the whole assembly is screwed with 2 pcs of bolts S 10X70 + 4 pcs of washer PD 10 + 2 pcs of M 10
- cable tray/ladder fastening to the bracket with bolts NSM 6X10

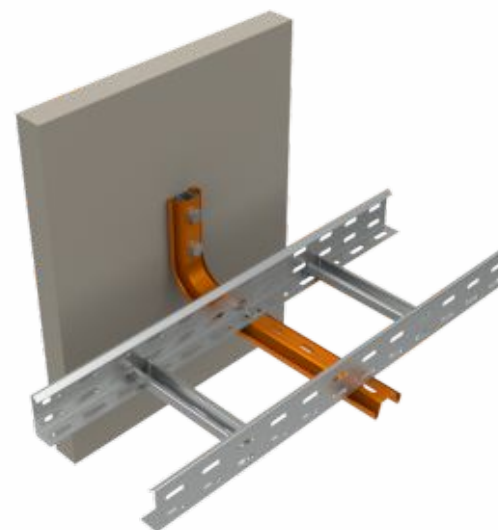

Product list for one mounting point - mounting to the wall	
LTS	1
STS	2
KPO 10X95	2
NSM 6X10	2

### hanging to the ceiling (floor)

- **SPL ceiling profile**
- the profile is fixed to the ceiling with 2 pcs of KPO 10X95 anchors or 2 pcs of KKZ 10 anchors + 2 pcs of S 10X40 bolts + 2 pcs of washers PD 10
- intended for DS, DT, DTN brackets hanging
- for single-sided mounting, the brackets are fastened with S 10X20 (S 10X25) bolts and PM 41 M 10 sliding nut (bolt and nut quantities are included in brackets instructions)
- for double-sided mounting, the brackets are fastened with bolts S 10X50, nuts M 10 and washers PD 10
- the number of brackets (routes) above each other is limited by the size of the profile and by the load capacity of the fastening material
- with respect to safety, it is advisable to provide the end of the bracket with OKSPL end seal



Product list for one mounting point - single-sided mounting			
SPL	1	SPL	1
KPO 10x95	2	KPO 10x95	2
KKZ 10 + S 10x40 + PD 10		KKZ 10 + S 10x40 + PD 10	
DS / DTN	1	DT	1
S 10x20 (S 10x25)	1	S 10x20 (S 10x25)	2
PM 41 M 10	1	PM 41 M 10	2
NSM 6x10	2	NSM 6x10	2
OKSPL	1	OKSPL	1

Product list for one mounting point - double-sided mounting			
SPL	1	SPL	1
KPO 10x95	2	KPO 10x95	2
KKZ 10 + S 10x40 + PD 10		KKZ 10 + S 10x40 + PD 10	
DS / DTN	2	DT	2
S 10x50	1	S 10x50	2
M 10	1	M 10	2
PD 10	1	PD 10	2
NSM 6x10	4	NSM 6x10	4
OKSPS	1	OKSPS	1

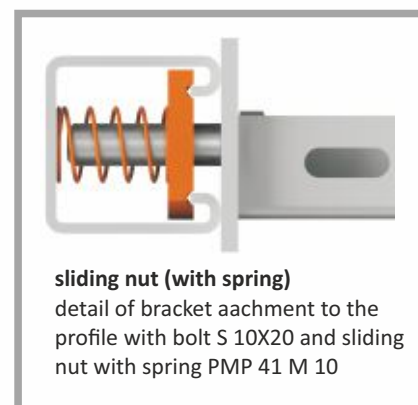

### hanging to the ceiling (floor)

- **SPS ceiling profile**
- the profile is fixed to the ceiling with 2 pcs of KPO 10X95 anchors or 2 pcs of KKZ anchors 10 + 2 pcs of S 10X40 bolts + 2 pcs of washers PD 10
- intended for DS, DT, DTN brackets hanging
- the brackets are fastened with S 10X20 (S 10X25) bolts and PM 41 M 10 or PMP 41 M 10 sliding nuts (bolts and nuts quantities are included in brackets instructions)
- for double-sided mounting, the brackets are fastened with bolts S 10X70, nuts M 10 and washers PD 10
- the number of brackets (routes) above each other is limited by the size of the profile and the load capacity of the fastening material
- with respect to safety it is advisable to provide the end of the bracket with OKSPS end seal

Product list for one mounting point - single-sided mounting			
SPS	1	SPS	1
KPO 10x95	2	KPO 10x95	2
KKZ 10 + S 10x40 + PD 10		KKZ 10 + S 10x40 + PD 10	
DS / DTN	1	DT	1
S 10x20 (S 10x25)	1	S 10x20 (S 10x25)	2
PM 41 M 10	1	PM 41 M 10	2
NSM 6x10	2	NSM 6x10	2
OKSPL	1	OKSPL	1

Product list for one mounting point - double-sided mounting			
SPS	1	SPS	1
KPO 10x95	2	KPO 10x95	2
KKZ 10 + S 10x40 + PD 10		KKZ 10 + S 10x40 + PD 10	
DS / DTN	2	DT	2
S 10x70	1	S 10x70	2
M 10	1	M 10	2
PD 10	1	PD 10	2
NSM 6x10	4	NSM 6x10	4
OKSPL	1	OKSPL	1



### hanging to the ceiling (floor)

- **SPT ceiling profile**
- the profile is fixed to the ceiling with 4 pcs of KPO 12X120 anchors or 4 pcs of KKZ 12 anchors + 2 pcs of bolts S 12X40 + 4 pcs of washers PD 12
- intended for DRT bracket hanging, the bracket is fixed to the profile with an angle piece, a nut and a bolt that are included in the packaging
- brackets together with profiles allow one-sided and double-sided mounting, even more floors above each other
- the number of brackets (routes) above each other is limited by the size of the profile and the load capacity of fastening material
- with respect to safety, it is advisable to provide the end of the bracket with OKSPT end seal



Product list for one mounting point - single-sided mounting	
SPT	1
KPO 12X120	4
KKZ 12 + S 12X40 + PD 12	
DRT	1
NSM 6X10	2
OKSPT	1

Product list for one mounting point - double-sided mounting	
SPT	1
KPO 12X120	4
KKZ 12 + S 12X40 + PD 12	
DRT	2
NSM 6X10	4
OKSPT	1

### hanging to the wall/ceiling

#### DS bracket (NIXDS, INOXDS)

- the bracket is fastened to the wall with 1 pcs of KPO 8x77 anchors
- the stainless steel bracket is fixed to the wall with 1 pcs of INOXKPO 8X75 anchors
- for hanging to the ceiling, the bracket is fastened to SPL or SPS ceiling profile with 1 pcs of bolts S 10X20 and 1 pcs of sliding nuts PM 41 M 10
- for double-sided mounting on SPL ceiling profile, the brackets are fixed with 1 pcs of bolts S 10X50, 1 pcs of M 10 and 1 pcs of PD 10 washers
- for double-sided mounting on SPS ceiling profile, the brackets are fixed with 1 pcs of S 10X70 bolts, 1 pcs of M 10 and 1 pcs of PD 10 washers
- cable tray (ladder) fastening to the bracket with bolts NSM 6X10 (NIXSM 6X10)
- SUP fixation clamp is suitable for cable ladder fastening



Product list for one mounting point - mounting to the wall	
DS (NIXDS, INOXDS)	1
KPO 8x77 (INOXKPO 8x75)	1
NSM 6x10 (NIXSM 6x10)	2

### hanging to the wall/ceiling

#### DT bracket

- the bracket is fastened to the wall with 2 pcs of KPO 10X95 anchors
- for hanging to the ceiling, the bracket is fastened to SPS ceiling profile with 2 pcs of bolts S 10X20 and 2 pcs of sliding nuts PM 41 M 10
- for double-sided mounting on SPS ceiling profile, the brackets are fixed with 2 pcs of S 10X70 bolts, 2 pcs of M 10 and 2 pcs of PD 10 washers
- cable tray (ladder) fastening to the bracket with bolts NSM 6X10
- SUP fixation clamp is suitable for cable ladder fastening

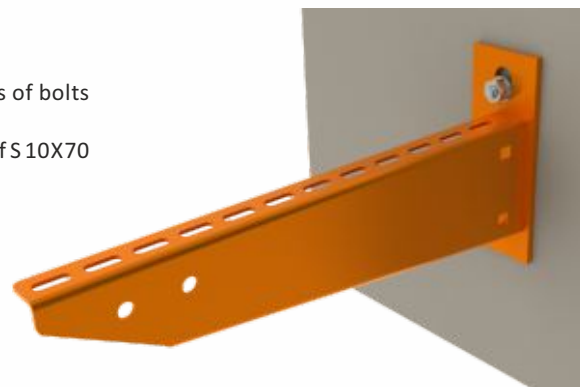

Product list for one mounting point - mounting to the wall	
DT	1
KPO 10x95	2
NSM 6x10	2

### mounting to the wall/ceiling

- **wall bracket - KLSU**
- the bracket is fastened to the wall with 1pc of KPO 8 anchor
- the cable ladder (tray) is fastened to the bracket with 2 pcs of NSM 6X10 bolts
- the bracket is used in pairs

Product list for one mounting point	
KLSU	2
KPO 8	2
KKZ 8 + S 8X40 + PD 8	2
NSM 6X10	4



### mounting to the wall/ceiling

- **distance bracket - KLDI 35X110**
- the bracket is fastened to the wall with 1 pc of KPO 8 anchor or 1 pc of KKZ 8 anchor + 1 pc of S 8X40 bolts + 1 pc of PD 8 washer
- the cable ladder (tray) is fastened to the bracket using 2 pcs of NSM 6X10 bolts
- the bracket is used in pairs
- grooves in the bracket allow the cable ladder to be offset from the wall 50, 75 or 100 mm

Product list for one mounting point	
KLDI	2
KPO 8	2
KKZ 8 + S 8X40 + PD 8	2
NSM 6X10	4

### mounting to the floor/wall

- **floor bracket VMB**
- the bracket is fastened to the floor with 2 pcs of KPO 10 anchors or 2 pcs of KKZ 10 anchors + 2 pcs of bolts S 10X40 + 2 pcs of washers PD 8
- cable tray (ladder) fastening to the bracket using 2 pcs of NSM 6X10 bolts

Product list for one mounting point	
VMB	1
KPO 10	2
KKZ 10 + S 10X40 + PD 10	
bolt into concrete	2
NSM 6X10	



### uchycení k podlaze

- **MP 41x41**
- the assembly profile is cut to the required length, e.g. using an angle grinder, the cutting has to be cleared off burrs and treated with zinc spray or paint
- the bracket is fastened to the floor with 2 pcs of KPO 10
- fastening of the cable tray to the support profile using a self-drilling screw STP

Product list for one mounting point - mounting to the wall	
MP 41x41	1
KPO 10	2
STP	2



### mounting on roofs

- **support washer for the roof PPS1 3XM8**
- the wire cable tray is attached to the support pad using the central hanger DZCZ (INOXDZCZ) and screw S 8x20 (INOXS 8x20)



### mounting on roofs

- **support washer for the roof PPS1 3XM8**
- the perforated cable tray is attached to the support pad using screw S 8x20 (INOXS 8x20) through the bottom of the tray



### mounting on roofs

- **support washer for the roof PPS1 3XM8**
- the pad can also be used as a base for attaching other support structures: mounting profiles, ceiling profiles, or structures made from threaded rod
- the ceiling profile is attached using 2 pads PPS1 3XM8 and 2 screws S 8x20



### mounting on roofs

- **support washer for the roof PPS1 L30**
- the cable tray is attached using a self-tapping screw STP 4.2x25 TX into the pressed rail





### cable fixing to the cable ladder

- **PKC1 cable clamp**
- size of the clamp is chosen according to the cable diameter
- fixture of the clamp is adapted for the direct mounting into the cable ladder partition wall
- the cable is firmly anchored using the bolt on the clamp to the cable ladder partition wall

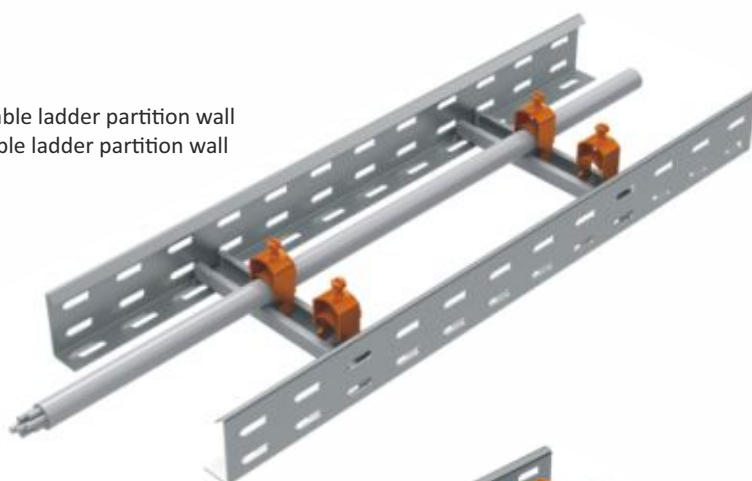

### cable fixing to cable trays

- **supporting profile for cable clamps NPKV + PKC1 cable clamp**
- for fastening the clamps to the tray it is necessary to use the supporting profile, it is fastened to the tray using 2 pcs of bolts NSM 6X10
- size of the clamp is chosen according to the cable diameter
- fixture of the clamp is adapted for the direct mounting into the supporting profile
- the cable is firmly anchored using the screw on the clamp to the cable ladder partition wall

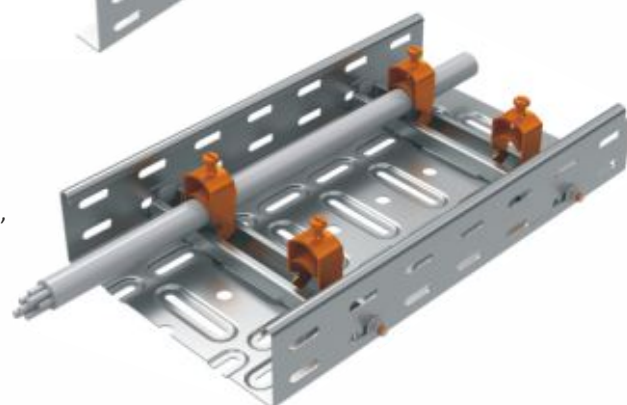

number of item	diameter min.-max. (mm)	route covering *				max. quantity of clamps side by side **					
		height of KZI, KL NKZI				KZI, KL width					
		60	85	110	100	150	200	300	400	500	600
<b>PKC1 1198</b>	6-12	yes	yes	yes	yes	8	12	18	24	30	37
<b>PKC1 1199</b>	7-16	yes	yes	yes	yes	7	9	14	19	24	29
<b>PKC1 1200</b>	10-19	no	yes	yes	yes	5	7	11	15	19	23
<b>PKC1 1201</b>	14-23	no	yes	yes	yes	5	6	10	14	17	21
<b>PKC1 1202</b>	20-26	no	yes	yes	yes	4	5	8	11	14	17
<b>PKC1 1203</b>	24-30	no	yes	yes	yes	3	5	7	10	12	15
<b>PKC1 1204</b>	25-34	no	yes	yes	yes	3	4	6	9	11	14
<b>PKC1 1205</b>	29-38	no	yes	yes	yes	3	4	6	8	10	13
<b>PKC1 1206</b>	32-43	no	no	yes	yes	2	3	5	7	9	11
<b>PKC1 1207</b>	42-46	no	no	yes	no	2	3	5	7	8	10
<b>PKC1 1208</b>	44-50	no	no	yes	no	2	3	5	6	8	10
<b>PKC1 1209</b>	50-54	no	no	yes	no	2	3	4	6	7	9
<b>PKC1 1210</b>	52-58	no	no	ne	no	2	2	4	5	7	8
<b>PKC1 1211</b>	55-63	no	no	ne	no	1	2	4	5	6	8
<b>PKC1 1212</b>	59-69	no	no	no	no	1	2	3	5	6	7

route covering



\* The table shows the possibility of the cable route covering with a cover when using a clamp with the maximum cable diameter.

\*\* The values indicate the maximum quantity of cable clamps of one size installed side by side compared with the ladder (tray) width. The number of installed cables is the same as the number of clamps.

Max. diameter + 2 mm is the outer width of the clamp. Using the outer clamp width it is possible to calculate the number of clamps when different sizes are required in one route.

### sets of support systems

- support constructions can be set from MP 41X41 and MP 41X21 assembly profiles
- VS 41X.. assembly accessories are intended for assembly profiles connecting and combining
- assembly accessories fastening to the assembly profile with screws S 10X20, S10X25, S 10X30, S 12X20, S 12X25 or S 12X30 and sliding nut PM 41 M 10 or PM 41 M 12
- the assembly profile is cut to the required length, e.g. using an angle grinder, the cutting has to be cleared off burrs and treated with zinc spray or paint

VS 41X03_F 	VS 41X05_F 	VS 41X06_F 	VS 41X08_F 
VS 41X12_F 	VS 41X13_F 	VS 41X16_F 	VS 41X17_F 
VS 41X18_F 	VS 41X20_F 	VS 41X27_F 	VS 41X31_F 
VS 41X36_F 	VS 41X37_F 	HMP 41 	
VS 41X41_F 	VS 41X43_F 	<ul style="list-style-type: none"> <li>▪ the HMP 41 head is used in combination with the MP 41X41 or MP 41X21 mounting profiles to create a ceiling profile (holder) of any length or to mount the profile to the floor</li> <li>▪ the MP 41X41 mounting profile is fastened to the head using S 10X70 bolts, M10 nuts and PD10 washers</li> <li>▪ the MP 41X21 mounting profile is fastened to the head using S 10X50 bolts, M10 nuts and PD10 washers</li> </ul> 	

Mounting thickness max. 5 mm.



KOPOS